



SOUTHERN CALIFORNIA EDISON COMPANY
 NET ENERGY METERING AND RENEWABLE ELECTRICAL GENERATING
 FACILITY INTERCONNECTION AGREEMENT FOR GENERATING
 FACILITIES SIZED ONE MEGAWATT AND SMALLER

This Net Energy Metering (NEM) and Renewable Electrical Generating Facility Interconnection Agreement ("Agreement") is entered into by and between County of Tulare ("Customer"), and Southern California Edison Company ("SCE"), sometimes also referred to herein jointly as "Parties" or individually as "Party."

1. APPLICABILITY

This Agreement is applicable only to Customers who satisfy all requirements of the definition of a Renewable Electrical Generating Facility ("Generating Facility") sized one megawatt (MW) and smaller as set forth in paragraph 1 of subdivision (a) of Section 25741 of the California Public Resources Code and all conditions and requirements as specified in Schedule NEM and its successor, Schedule NEM-ST.

2. SUMMARY OF GENERATING FACILITY AND CUSTOMER ACCOUNT

- | | | |
|-----|--|---|
| 2.1 | Generating Facility Identification Number: | <u>NST-16552</u> |
| 2.2 | Customer Meter Number: | <u>V349N-016039</u> |
| 2.3 | Customer Service Account Number: | <u>3-044-9387-27</u> |
| 2.4 | Applicable Rate Schedule: | <u>TOU-8-B</u> |
| 2.5 | Generating Facility Location: | <u>5300 W Tulare Ave, Visalia, CA 93277</u> |

2.5.1 This agreement is applicable only to the Generating Facility described below and installed at the above location. The Generating Facility may not be relocated or connected to SCE's system at any other location without SCE's express written permission.

2.5.2 This Agreement is applicable only to Renewable Electrical Generating Facilities, which includes biomass, solar thermal, photovoltaic, wind, geothermal, fuel cells (using renewable fuel), small hydroelectric generation, digester gas, municipal solid waste conversion, landfill gas, ocean wave, ocean thermal, or tidal current, and any additions or enhancements using such technology.

2.5.3 Renewable Electrical Generating Facilities using fuel cells, municipal solid waste conversion, and small hydroelectric generating will be required to sign an Affidavit (Form 14-912) certifying the following criteria have been met:

- a) For purposes of this Agreement, qualifying "solid waste conversion" is defined pursuant to Public Resources Code Section 25741(b)(3).
- b) For purposes of qualifying under "fuel cell" using renewable fuels, the Generating Facility must use technology the California Public Utilities Commission ("Commission") determines will achieve reductions in emissions of greenhouse gases and meet emissions requirements for eligibility for funding pursuant to the Self-Generation Incentive Programs.
- c) A "small hydroelectric" generating facility is not an eligible Generating Facility if it will cause an adverse impact on instream beneficial uses or cause a change in the volume or timing of streamflow.

- | | | |
|-----|--|---------------------------------|
| 2.6 | Generating Facility Technology (technologies using the renewable resources reflected above): | <u>Solar Photovoltaics (PV)</u> |
|-----|--|---------------------------------|



SOUTHERN CALIFORNIA EDISON COMPANY
 NET ENERGY METERING AND RENEWABLE ELECTRICAL GENERATING
 FACILITY INTERCONNECTION AGREEMENT FOR GENERATING
 FACILITIES SIZED ONE MEGAWATT AND SMALLER

2.7	Generating Facility Nameplate Rating (kW):	<u>850</u>
2.8	Generating Facility CEC-AC Rating or Equivalent (kW):	<u>888.316</u>
2.9	Estimated monthly energy production of Generating Facility (kWh):	<u>128,191.83</u>

3. METERING AND BILLING:

3.1 Metering requirements and billing procedures shall be set forth in SCE's, Electric Service Provider's and/or Community Choice Aggregator's/Community Aggregator's rate schedule(s) applicable to the electric service account assigned to the location where the Generating Facility is connected.

3.2 MONTHLY BILLING ELECTION:

By default, Residential and Small Commercial NEM Customers are billed (i.e., required to pay) ANNUALLY for their energy charges. However, the provisions of Schedules NEM and NEM-ST provide that "Upon a Customer's request, SCE shall permit a Residential or Small Commercial Customer to pay all applicable energy charges monthly.

Customers on monthly billing will receive monthly bill statements showing both the energy and non- energy related billing components and corresponding charges, and will be required to pay any positive energy charges monthly.

Having considered billing options that are available, I hereby request for monthly billing for the Customer Service Account Number listed above. _____ (initial here)

4. GENERATING FACILITY INTERCONNECTION AND DESIGN REQUIREMENTS:

4.1 Customer shall be responsible for the design, installation, operation, and maintenance of the Generating Facility and shall obtain and maintain any required governmental authorizations and/or permits.

4.2 The Generating Facility shall meet all applicable safety and performance standards established by the National Electrical Code, the Institute of Electrical and Electronics Engineers ("IEEE"), and accredited testing laboratories such as Underwriters Laboratories ("UL"), and, where applicable, rules of the Commission regarding safety and reliability. This requirement shall include, but not be limited to, the provisions of IEEE Standard 929, UL Standard 1741 and SCE's Electric Rule 21 – Generating Facility Interconnections.

4.3 For Customers interconnecting a Generating Facility under the provisions of Schedule NEM-ST, the Generating Facility must have a warranty of at least 10 years for all equipment and the associated installation from the system provider. In appropriate circumstances conforming to industry practice, this requirement may rely on and be satisfied by manufacturers' warranties for equipment and separate contractors' warranties for workmanship (i.e., installation). Warranties or service agreements conforming to requirements applicable to the Self-Generation Incentive Program ("SGIP") may also be used for technologies eligible for the SGIP.

4.4 For Customers interconnecting a solar Generating Facility under the provisions of Schedule NEM-ST, all major solar system components (including PV panels and other generation equipment, inverters and meters) must be on the verified equipment list maintained by the California Energy Commission ("CEC"). For all NEM-ST Generating



SOUTHERN CALIFORNIA EDISON COMPANY
 NET ENERGY METERING AND RENEWABLE ELECTRICAL GENERATING
 FACILITY INTERCONNECTION AGREEMENT FOR GENERATING
 FACILITIES SIZED ONE MEGAWATT AND SMALLER

Facilities, any other equipment, as determined by SCE, must be verified as having safety certification from a Nationally Recognized Testing Laboratory ("NRTL").

- 4.5 Customer shall not commence parallel operation of the Generating Facility until written approval has been provided to it by SCE. SCE shall normally provide such written approval no later than 30 business days following SCE's receipt of (1) a completed Net Energy Metering Application including all supporting documents and required payments, (2) a completed signed Net Energy Metering Interconnection Agreement, and (3) evidence of the Applicant's final electric inspection clearance from the Local Authority having jurisdiction over the Generating Facility. If the 30-day period cannot be met, SCE shall notify Applicant and the Commission of the reason for the inability to process the interconnection request and the expected completion date.
- 4.6 SCE shall have the right to have its representatives present at the final inspection made by the governmental authority having jurisdiction to inspect and approve the installation of the Generating Facility.
- 4.7 Customer shall not add generation capacity in excess of the ratings set forth in Sections 2.7 and 2.8 of this Agreement, or otherwise modify the Generating Facility without the prior written permission of SCE.
- 4.8 Customers interconnecting inverter-based Generating Facilities are required to comply with the requirements of Section Hh of SCE's Electric Rule 21, including configuration of protective settings in accordance with the specifications therein. Verification of compliance with such requirements shall be provided by the Customer upon request by SCE in accordance with SCE's Electric Rule 21.

5. DISCONNECTION, INTERRUPTION OR REDUCTION OF DELIVERIES:

- 5.1 SCE may require Customer to interrupt or reduce the output of its Generating Facility under the following circumstances:
 - (a) Whenever SCE deems it necessary in its sole judgment, to construct, install, maintain, repair, replace, remove, investigate, or inspect any of its equipment or any part of its electric system; or
 - (b) Whenever SCE determines in its sole judgment, that curtailment, interruption, or reduction of Customer's electrical generation is otherwise necessary due to emergencies, forced outages, force majeure, or compliance with prudent electrical practices.
- 5.2 Notwithstanding any other provision of this Agreement, upon termination of this Agreement or at any time SCE determines the continued parallel operation of the Generating Facility may endanger the public or SCE personnel, or affect the integrity of SCE's electric system or the quality of electric service provided to other customers, SCE shall have the right to require the Generating Facility to be immediately disconnected from SCE's electric system. The Generating Facility shall remain disconnected until such time as SCE is satisfied, in its sole judgment, that the condition(s) causing such disconnection have ended or have been corrected.
- 5.3 Whenever feasible, SCE shall give Customer reasonable notice of the possibility that interruption or reduction of deliveries may be required.
- 5.4 Electrical energy and capacity provided to Customer during periods of curtailment or interruption of the output of the Generating Facility shall be provided pursuant to the



SOUTHERN CALIFORNIA EDISON COMPANY
NET ENERGY METERING AND RENEWABLE ELECTRICAL GENERATING
FACILITY INTERCONNECTION AGREEMENT FOR GENERATING
FACILITIES SIZED ONE MEGAWATT AND SMALLER

terms of the rate schedule(s) applicable to the electric service account to which the Generating Facility is connected.

6. ACCESS TO PREMISES:

SCE may enter Customer's premises at all times, without notice to Customer for emergency purposes only.

- (a) To inspect Customer's protective devices or check meter(s); to ascertain there is no power flow; or
- (b) To disconnect the Generating Facility and/or service to Customer, whenever in SCE's discretion, a hazardous condition exists and such immediate action is necessary to protect persons, SCE's facilities, or property of others from damage or interference caused by the Generating Facility, or the failure of properly operating protective devices.

SCE will make prior arrangements with the Customer for gaining emergency access to Customer's premises by obtaining keys to a lock box or a padlock or by making other mutually agreeable arrangements.

7. INDEMNITY AND LIABILITY:

- 7.1 Each Party as indemnitor shall defend, hold harmless, and indemnify the other Party and the directors, officers, employees, and agents of the other Party against and from any and all loss, liability, damage, claim, cost, charge, demand, or expense (including any direct, indirect or consequential loss, liability, damage, claim, cost, charge, demand, or expense, including attorneys' fees) for injury or death to persons, including employees of either Party, and damage to property, including property of either Party, arising out of or in connection with (a) the engineering, design, construction, maintenance, repair, operation, supervision, inspection, testing, protection or ownership of the indemnitor's facilities, or (b) the making of replacements, additions, betterments to, or reconstruction of the indemnitor's facilities. This indemnity shall apply notwithstanding the active or passive negligence of the indemnitee. However, neither Party shall be indemnified hereunder for its loss, liability, damage, claim, cost, charge, demand, or expense resulting from its sole negligence or willful misconduct.
- 7.2 The indemnitor shall, on the other Party's request, defend any suit asserting a claim covered by this indemnity and shall pay for all costs, including reasonable attorney fees, that may be incurred by the other Party in enforcing this indemnity.
- 7.3 The provisions of this Section shall not be construed to relieve any insurer of its obligations to pay any insurance claims in accordance with the provisions of any valid insurance policy.
- 7.4 Except as otherwise provided in Section 7.1, neither Party shall be liable to the other Party for consequential damages incurred by that Party.
- 7.5 Nothing in this Agreement shall create any duty to, any standard of care with reference to, or any liability to any person who is not a Party to it.
- 7.6 Notwithstanding the provisions of Section 7.1, Customer shall be responsible for protecting its Generating Facility from damage by reason of the electrical disturbances or



SOUTHERN CALIFORNIA EDISON COMPANY
NET ENERGY METERING AND RENEWABLE ELECTRICAL GENERATING
FACILITY INTERCONNECTION AGREEMENT FOR GENERATING
FACILITIES SIZED ONE MEGAWATT AND SMALLER

faults caused by the operation, faulty operation, or non-operation of SCE's facilities, and SCE shall not be liable for any such damage so caused.

8. GOVERNING LAW:

This Agreement shall be interpreted, governed, and construed under the laws of the State of California as if executed and to be performed wholly within the State of California.

9. CALIFORNIA PUBLIC UTILITIES COMMISSION:

9.1 This Agreement shall at all times be subject to such changes or modifications by the Commission as the Commission may, from time to time, direct in the exercise of its jurisdiction.

9.2 Notwithstanding any other provisions of this Agreement, SCE has the right to unilaterally file with the Commission, pursuant to the Commission's rules and regulations, an application for change in rates, charges, classification, service, or rule or any agreement relating thereto.

10. AMENDMENT, MODIFICATIONS, WAIVER OR ASSIGNMENT:

10.1 This Agreement may not be altered or modified by either of the Parties, except by an instrument in writing executed by each of them.

10.2 None of the provisions of this Agreement shall be considered waived by a Party unless such waiver is given in writing. The failure of a Party to insist in any one or more instances upon strict performance of any of the provisions of this Agreement or to take advantage of any of its rights hereunder shall not be construed as a waiver of any such provisions or the relinquishment of any such rights for the future, but the same shall continue and remain in full force and effect.

10.3 This Agreement shall supersede any existing agreement under which Customer is currently operating the Generating Facility identified in Section 2, herein, and any such agreement shall be deemed terminated as of the date this Agreement becomes effective.

10.4 This Agreement contains the entire agreement and understanding between the Parties, their agents, and employees as to the subject matter of this Agreement. Each party also represents that in entering into this Agreement, it has not relied on any promise, inducement, representation, warranty, agreement or other statement not set forth in this Agreement.

10.5 A new Customer of Record or New Party In ("NPI") who owns, leases, or rents a premises with an operating NEM Generating Facility, previously approved by SCE for Parallel Operation, does not have to submit a new interconnection agreement as long as the Customer meets the requirements of Schedule NEM or its successor, Schedule NEM-ST, as applicable. This will also apply to premises where the developer/contractor establishes the interconnection, so that the Customer who buys/rents/leases the premises will not have to re-submit and sign a new interconnection agreement.

A new Customer of Record or NPI, who owns, rents or leases a premises that includes NEM Generating Facilities with a capacity of 30 kW or less, that were approved by SCE for Parallel Operation prior to the new Customer or NPI moving in and/or taking electric service with SCE will take service on Schedule NEM or its successor, Schedule NEM-ST, as applicable, as long as the requirements of this section are met in accordance with the transition provisions contained in Schedules NEM and NEM-ST, as applicable. To be



SOUTHERN CALIFORNIA EDISON COMPANY
NET ENERGY METERING AND RENEWABLE ELECTRICAL GENERATING
FACILITY INTERCONNECTION AGREEMENT FOR GENERATING
FACILITIES SIZED ONE MEGAWATT AND SMALLER

eligible, the new Customer or NPI must (1) ensure that the Generating Facility is compliant with all applicable safety and performance standards as delineated in SCE's Electric Rule 21 and other applicable tariffs in effect at the time of initial approval for Parallel Operation; (2) keep in force the amount of property, commercial general liability and/or personal liability insurance the NPI or new Customer has in place at the time it initiates service on this tariff; and, (3) understand that SCE may from time to time release to the CEC and/or the Commission, information regarding the new Customer or NPI's Generating Facility, including NPI or new Customer's name and Generating Facility location, capacity and operational characteristics. SCE will provide the NPI or new Customer with (i) a copy of the interconnection agreement in effect and as signed by the previous customer, which will remain unchanged, (ii) a copy of the NEM Fact Sheet on operation and billing, and (iii) SCE's website information on the NEM or NEM-ST tariffs.

10.6 A new Customer or NPI who owns, rents or leases a premises that includes a NEM Generating Facility above 30 kW will need to sign a new interconnection agreement. If no changes are made to the interconnection facilities, the agreement will have identical terms and conditions as the ones approved for the previous customer.

11. NOTICES:

11.1 Any notice required under this Agreement shall be in writing and mailed at any United States Post Office with postage prepaid and addressed to the Party, or personally delivered to the Party, at the address below. Changes in such designation may be made by notice similarly given. All written notices shall be directed as follows:

SOUTHERN CALIFORNIA EDISON COMPANY:
Attn: NEM Program Administrator
SCE Customer Solar & Self Generation
P.O. Box 800
Rosemead, CA 91770

COUNTY OF TULARE:
Attn: John Hess, Agency Director
5959 S Mooney Blvd.
Visalia, CA 93277

11.2 Customer's notices to SCE pursuant to this Section shall refer to the Generating Facility Identification Number that is set forth in Section 2.1

12. TERM AND TERMINATION OF AGREEMENT:

12.1 This Agreement shall become effective when SCE issues written authorization to interconnect the Generating Facility after receipt of all required documents and payments, and this completed Agreement signed by the Customer and SCE, and shall remain in effect thereafter from month to month unless terminated by either Party on thirty (30) days' prior written notice in accordance with Section 11.

12.2 This Agreement shall terminate, without notice, upon: (a) termination of the electric distribution service provided to Customer by SCE; or (b) changes to Customer's electric load which cause Customer to no longer satisfy all requirements of the definition of an Eligible Customer-Generator, as set forth in Sections 2827(b)(4) or 2827.1(a) of the California Public Utilities Code; or (c) termination of Customer's NEM arrangements with its Electric Service Provider, Community Choice Aggregator or Community Aggregator.



SOUTHERN CALIFORNIA EDISON COMPANY
NET ENERGY METERING AND RENEWABLE ELECTRICAL GENERATING
FACILITY INTERCONNECTION AGREEMENT FOR GENERATING
FACILITIES SIZED ONE MEGAWATT AND SMALLER

13. TRANSITION PROVISIONS:

- 13.1 Customers receiving service on Schedule NEM, or who have submitted all documentation necessary for receiving service on Schedule NEM, prior to SCE reaching its NEM trigger level or July 1, 2017, whichever is earlier, are subject to the transition provisions as outlined in Schedule NEM.
- 13.2 Customers receiving service on Schedule NEM-ST, or who have submitted all documentation necessary for receiving service on Schedule NEM-ST, are subject to the transition provisions as outlined in Schedule NEM-ST.

14. SIGNATURES:

This Agreement may be executed in counterparts, and by Electronic Signature on the part of SCE and/or the Customer, and copies of a Party's signed signature page may be transmitted to the other Party by facsimile or other electronic means. Copies of the signature page so transmitted may be used for the purpose of enforcing the terms of this Agreement as though they were originals and will not be made inadmissible in any legal or regulatory proceeding concerning this Agreement on the basis of the Best Evidence Rule or similar rule of admissibility.

IN WITNESS WHEREOF, the Parties hereto have caused this Agreement to be executed by their duly authorized representatives. This Agreement is effective as provided in Section 12.1 above.

CUSTOMER

By: _____
 Name: _____
 Title: Chairman, County of Tulare
 Board of Supervisors
 Date: _____

SOUTHERN CALIFORNIA EDISON COMPANY

By:  _____
 Name: Marcus Lotto
 Title: Senior Manager, Grid Interconnection
 and Contract Development
 Date: 1/27/2019

50kW INVERTER EQUIPMENT RATING

INVERTER MANUFACTURER	CPS
INVERTER MODEL NUMBER	SCA50KTL-DO/US-480
TOTAL NUMBER OF INVERTERS	5
INVERTER EFFICIENCY	98.5%
MAX CURRENT OUTPUT	60.2A
VOLTAGE OUTPUT	3ø, 480V
MAX SYSTEM VOLTAGE	1000 VDC

60kW INVERTER EQUIPMENT RATING

INVERTER MANUFACTURER	CPS
INVERTER MODEL NUMBER	SCA60KTL-DO/US-480
TOTAL NUMBER OF INVERTERS	10
INVERTER EFFICIENCY	98.5%
MAX CURRENT OUTPUT	72.2A
VOLTAGE OUTPUT	3ø, 480V
MAX SYSTEM VOLTAGE	1000 VDC

GENERAL NOTES

- CONTRACTOR TO INSTALL DATA ACQUISITION SYSTEM AND WEATHER STATION CONDUIT, WIRE, AND HARDWARE PER UTILITY AND MANUFACTURER REQUIREMENTS.
- THE COMPLETE SYSTEM (E.G., INVERTERS, PANELBOARDS, SWITCHBOARDS, AND DISCONNECTS) SHALL BE FULLY RATED FOR THE AVAILABLE FAULT CURRENT.
- WORST CASE FOR VOLTAGE DROP FROM PV STRING TO INVERTER IS X.XX% BASED ON #10 (CU) PV WIRE.
- SEE SHEETS EB.0 THROUGH EB.1 FOR EQUIPMENT CUT SHEETS.
- SEE SHEET E2.1 FOR ALL DC AND AC WIRING CALCULATIONS.
- EXPOSED WIRES MUST BE PV-WIRE TYPE IN UNGROUNDED DC SYSTEMS PER CEC 690.35(D).
- GEC TO BE CONTINUOUS AS PER CEC 690.47 & 250.64(C).
- ALL BREAKERS AND DISCONNECT SWITCHES ARE CLOSED UNDER NORMAL OPERATING CONDITIONS UNLESS OTHERWISE NOTED.
- LABELING OF GENERATION EQUIPMENT SHALL CONFORM TO DSA AND NEC REQUIREMENTS.
- ALL INVERTER WIRING AND GROUNDING METHODS SHALL CONFORM TO THE MANUFACTURER'S RECOMMENDED PRACTICES. REFER TO PLANNING AND INSTALLATION MANUAL FOR GUIDE.
- CONDUCTORS SHALL NOT BE ROUTED THROUGH SWITCHGEAR UTILITY METERING SECTION.
- THE MAXIMUM ALLOWABLE SYSTEM VOLTAGE DROP IS 1.5% MAX AC AND 1.5% MAX DC.

REFERENCE NOTES

- PV INPUT BREAKERS ARE SIZED TO CARRY 125% OF CONTINUOUS CURRENT PER INVERTER DATA SHEET.
- FUSED, VISIBLE-OPEN, LOCKABLE AC DISCONNECT WITH VISIBLE BLADES IN COMPLIANCE WITH RULE 21. OPERATING HANDLE SHALL BE NO HIGHER THAN 6'-7" ABOVE GRADE WHEN THE HANDLE IS IN IT'S HIGHEST POSITION. VERIFY INSTALLATION STANDARDS WITH SCE.
- FIELD VERIFY ACTUAL CONNECTION POINT. PV SYSTEM POINT OF CONNECTION SHALL BE ON THE SUPPLY SIDE OF THE EXISTING MAIN SWITCHBOARD, AS REQUIRED BY AHJ, THROUGH A NATIONALLY RECOGNIZED TESTING LABORATORY. INSTALL PER NEC 705.12(A) AND 705.31. PROVIDE CABLE LIMITERS WHERE TAP CONDUCTORS ARE LONGER THAN 10'. CABLE LIMITERS SHALL BE FERRAZ-SHAMMUT "CP", TYPE 3, OR EQUAL.
- REDUCED NEUTRAL SIZE AS PER NEC 250.24(C)(1) NEUTRAL WIRE IS ONLY PROVIDED FOR INVERTER SYSTEM REFERENCE. CONNECTED LOADS DO NOT REQUIRE A NEUTRAL.
- SEE DETAILS #1 THROUGH #5 ON SHEET E6.0 AND #3 THROUGH #4 ON SHEET E6.2 FOR GROUNDING CONDUCTOR CONNECTIONS.
- SEE STRUCTURAL DRAWINGS SXX AND SXX AND DETAIL #5 ON SHEET E8.1 FOR MODULE GROUNDING METHOD.
- METER AND DAS EQUIPMENT PROVIDED BY ENGIE ENERGY. SEE SHEET E2.2 AND DETAIL #1 ON SHEET E8.1.
- SEE SHEET E2.2 FOR COMMUNICATION WIRING. PROVIDE CONDUIT AND RS-485 CABLES FOR PV MONITORING SYSTEM. COMMUNICATION CABLES SHALL BE SUITED FOR WET LOCATION AND SHALL BE UL LISTED AND LABELED. REFER TO MANUFACTURER'S INSTALLATION MANUAL FOR CABLE TYPES.
- 5KVA, 480-120V, 1ø, TRANSFORMER - SQUARE D OR EQUAL PROVIDE 1#8 GEC (CU) TO NEAREST BUILDING STEEL OR ARRAY COLUMN.
- WIRELESS CELLULAR COMMUNICATION.
- 1/2"C-4#12 + 1#12 GND.
- 1/2"C-2#12 + 1#12 GND.
- 1/2"C-6#16 (CU) FOR CURRENT TRANSFORMERS.
- EXISTING SCE METER #V349N-016039
- METER TO BE BI-DIRECTIONAL. VERIFY AND REQUEST FOR UTILITY TO REPLACE AS NECESSARY.
- FIELD VERIFY ACTUAL CONNECTION POINT. BATTERY STORAGE SYSTEM POINT OF CONNECTION SHALL BE ON THE LOAD SIDE OF THE EXISTING MAIN SWITCHBOARD 3000A BUS SECTION. CONTRACTOR SHALL PROVIDE RE-CERTIFICATION, AS REQUIRED BY AHJ, OF THE EXISTING SWITCHBOARD THROUGH A NATIONALLY RECOGNIZED TESTING LABORATORY. INSTALL PER NEC 705.12(D).
- REPLACE EXISTING 3000 RATING PLUG WITH NEW 2100A RATING PLUG. PEAK POWER DEMAND IS 808kW IN THE LAST 12 MONTHS. MAIN BREAKER TRIP AT 2100A IS BASED ON THE PEAK POWER DEMAND PLUS 90% FUTURE LOAD GROWTH.
- FLOW SENSING RELAY. ONCE THE MONITORING SYSTEM SENSES THAT CURRENT IS FLOWING BACK TO GRID, RELAY SHALL TRIGGER THE ESS BATTERY SHUNT TRIP BREAKERS TO OPEN.

SOLAR PANEL EQUIPMENT RATING

MODULE	LG NEON 2 LG400N2W-A5
TOTAL NUMBER OF MODULES	2448
STC WATTAGE RATING	400W
PTC WATTAGE RATING	368.4W
MAX POWER VOLTAGE	40.6V
MAX POWER CURRENT	9.86A
OPEN CIRCUIT VOLTAGE	49.3V
SHORT CIRCUIT CURRENT	10.47A
MAX SYSTEM VOLTAGE	1500VDC

DC SYSTEM WATTAGE

2,448 MODULES X 400W = 979.2 KWDC

AC SYSTEM WATTAGE

(2448 x 368.4 x 98.5%) = 888.3 KWAC

INVERTER OUTPUT WATTAGE

(5)50kW+(10)60kW= 850 KWAC

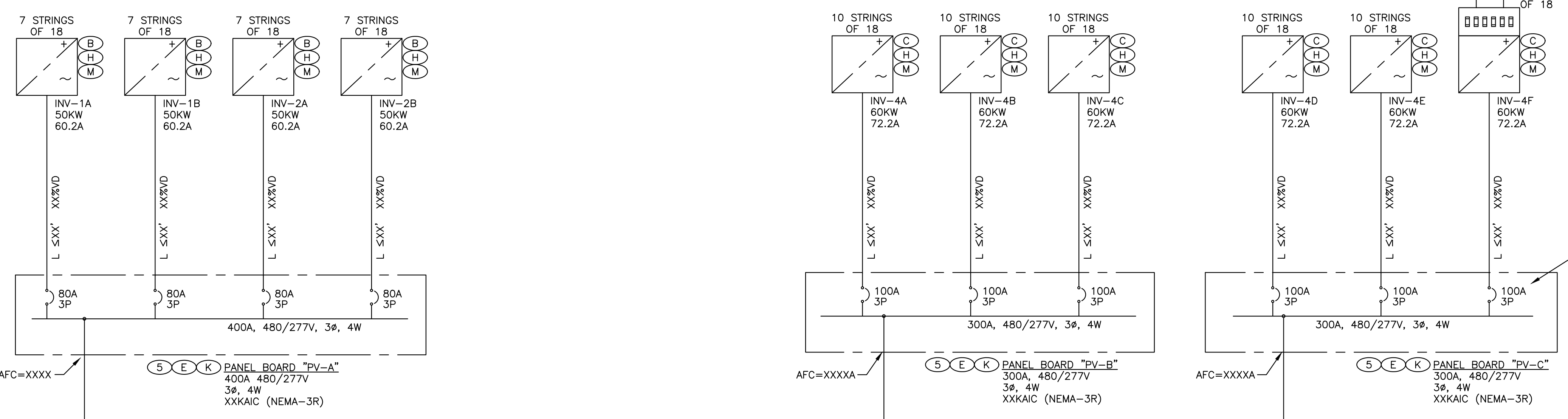

DRAWING NOTES:

ALL LINES, TEXT, SYMBOLS, ETC. SHOWN AS FADED ARE EXISTING TAKEN FROM RECORD DRAWINGS

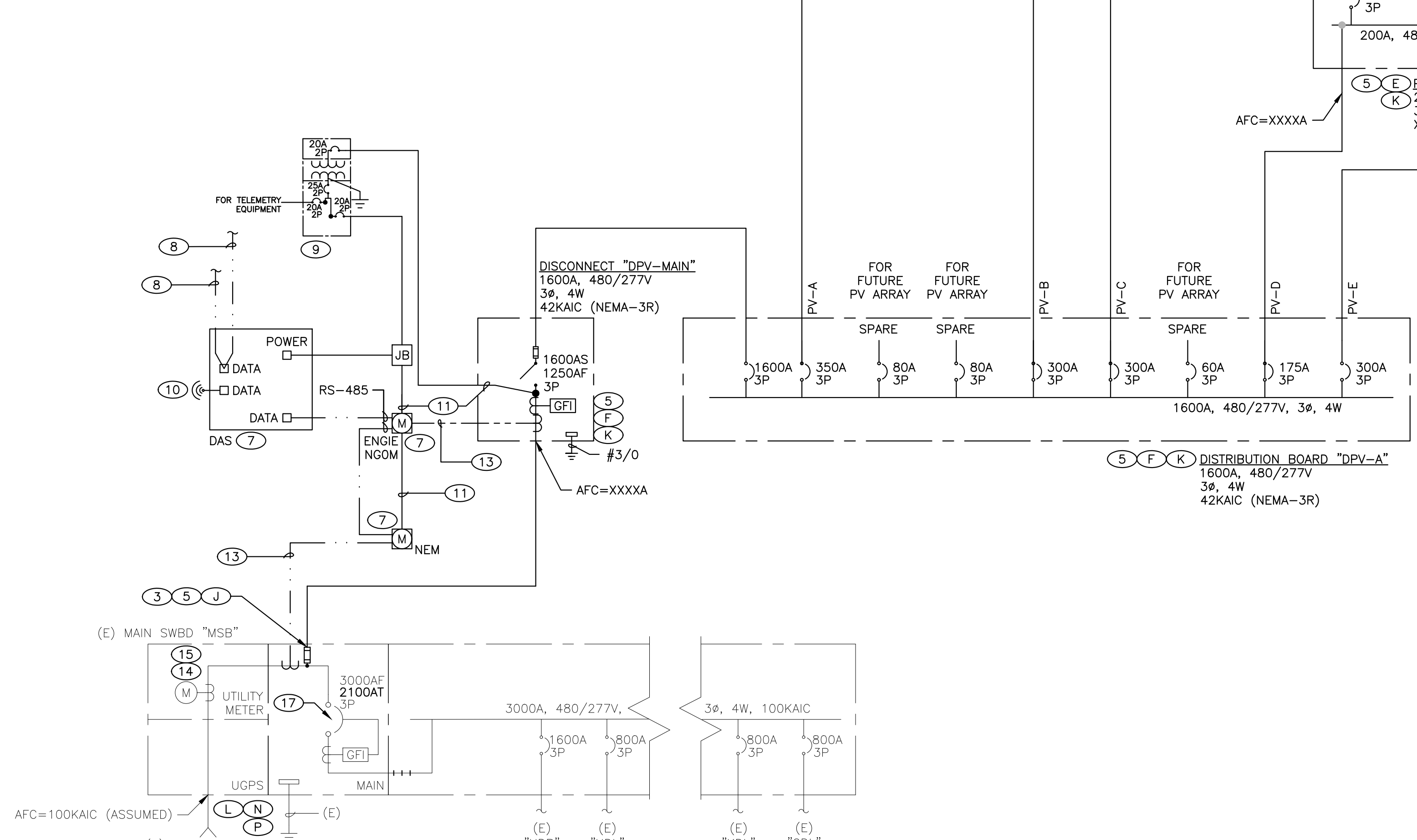

1 SINGLE LINE DIAGRAM

SCALE: NONE

CLIENT
 TULARE COUNTY CALIFORNIA

DESIGNER
 ENGIE SERVICES U.S.
 PASADENA, CALIFORNIA OFFICE
 150 E. COLORADO BLVD, SUITE 360
 Tel 626 377 4948
 Fax 626 377 5978

PROJECT LOCATION
 TULARE AKRES PROFESSIONAL CENTER
 5300 WEST TULARE AVENUE
 VISALIA, CA 93277

STRUCTURAL ENGINEER
 mbl energy
 1698 ROGERS AVE, SUITE 40
 SAN JOSE, CA 95112
 Tel 408 467 0150

ELECTRICAL ENGINEER
 CSI
 ELECTRICAL CONTRACTORS, INC.
 10623 Fulton Woods Avenue
 Newark, CA 94761
 510 948 0700
Some drawings and written materials contained on this document are the original, preparation and copyright work of CSI Electrical Contractors, Inc. and may not be duplicated, modified or re-used without the written consent of CSI Electrical Contractors, Inc.

ELECTRICAL ENGINEER
 REGISTERED PROFESSIONAL ENGINEER
 RAUL DELOS SANTOS
 REG.#200410
 EXP. 09/30/19
 ELECTRICAL
 STATE OF CALIFORNIA

AGENCY APPROVAL

ISSUE

MARK	DATE	DESCRIPTION
	10/12/18	SCE SUBMISSION

DRAWN BY: _____
 CHECKED BY: _____
 SCALE: AS NOTED

SHEET TITLE

SHEET NUMBER
TA-E2.0A

N:\Cad Files\180905.02 - Tulare Count PV\Tulare Akres\AutoCAD\Design\E2.0-E2.2 SINGLE LINE DIAGRAM